



ordini@primexitalia.org

www.primexitalia.org

CATALOGO MARZO 2023

Forniamo una vasta gamma di prodotti per la protezione individuale e dispositivi medici certificati da imprese produttive credibili ed affidabili



Qualità certificata



Migliori soluzioni di trasporto



Senza pensieri

INDICE

1. Mascherine FFP2 / FFP3/
Chirurgiche/ Protettive
2. Camici e tute di protezione
3. Occhiali a maschera / Occhiali a
stanghetta / Visiere
4. Guanti in nitrile
5. Test rapidi
6. Altro

1. Mascherine FFP2 / FFP3/ Chirurgiche/ Protettive

M36 (Primo Modello) – MASCHERINA FFP2



Sommario:

- Polipropilene non tessuto a 3 strati spun-bonded
- Design piatto piegato centrale, maschera ergonomica monouso
- Classe respiratoria: FFP2 / KN95
- Percentuale di filtraggio aerosol: $\geq 95\%$



Certificazioni:

- Certificato CEP
- rodoto e ispezionato in conformità con EU - EN149: 2001 + A1: 2009 / US - FDA, NIOSH Standard



720 pezzi / cartone



40 * 31 * 37 cm (cartone)



N.W. 4.7 KG / cartone



Luogo di fabbricazione: Shanghai, Cina

M36 (Secondo Modello) – MASCHERINA FFP2



Sommario:

- Polipropilene non tessuto a 3 strati spun-bonded
- Design piatto piegato centrale, maschera ergonomica monouso
- Classe respiratoria: FFP2 / KN95
- Percentuale di filtraggio aerosol: $\geq 95\%$



Certificazioni:

- Certificato CEP
- rodoto e ispezionato in conformità con EU - EN149: 2001 + A1: 2009 / US - FDA, NIOSH Standard



540 pezzi / cartone

5 pezzi / pacchetto
30 pezzi/scatola



40 * 31 * 37 cm (cartone)



G.W. 5.2 KG / cartone

N.W. 3.7 KG / cartone



Luogo di fabbricazione: Shanghai, Cina

M125 – MASCHERINA FFP2



Sommario:

- Polipropilene non tessuto a 3 strati spun-bonded
- Dispositivi di protezione delle vie respiratorie - Semimaschera filtrante
- Classe respiratoria: FFP2 / KN95
- Percentuale di filtraggio aerosol: $\geq 95\%$



Certificazioni:

- Certificato CEP
- rodoto e ispezionato in conformità con EU - EN149: 2001 + A1: 2009



1200 pezzi / cartone

30 pezzi/scatola



50 * 47 * 32 cm (cartone)



G.W. 9 KG / cartone

N.W. 8 KG / cartone



Luogo di fabbricazione: Luohe, Cina

M61 – MASCHERINA FFP3 PIEGHEVOLE



Sommario

- 4 strati, non tessuto spun-bonded, non tessuto soffiato a fusione
- Design piatto piegato centrale, maschera ergonomica monouso
- Classe respiratoria: FFP3
- Percentuale di filtrazione aerosol: $\geq 99\%$



Certificazioni:

- Certificato CE
- Prodotto e ispezionato in conformità con EU - EN149: 2001 + A1: 2009 / US - FDA, NIOSH Standard,
- GB2626: 2006



540 pezzi / cartone

5 pezzi / pacchetto
30 pezzi/scatola



42.5 * 33 * 36 cm (cartone)



G.W. 6.2 KG / cartone

N.W. 3.7 KG / cartone



Luogo di fabbricazione: Shanghai, Cina

M68 MASCHERINA FFP3 A CONCHIGLIA



Sommario

- Dispositivo di protezione individuale Particolare respiratore
- La filtrazione dell'aerosol blocca con successo qualsiasi particolato pericoloso o fastidioso nell'aria



Certificazioni:

- CE , NIOSH
- EN149:2001+A1:2009



400 pezzi / cartone

20 pezzi/ scatola



66.5 * 26.5 * 36 cm (cartone)



G.W. 6.1 KG / cartone



Luogo di fabbricazione: : Chuzhou, Anhui , Cina

M22 - Mascherina medica a 3 strati (tipo IIR)



Sommario

- Maschera medica monouso a 3 strati (tipo IIR), polipropilene non tessuto spun-bonded, impermeabile, pieghettato piatto
- Monouso, con elastici per le orecchie, clip per il naso
- Effetto di filtrazione batterica BEF: 98%



Certificazioni:

- CE (Dichiarazione di conformità) e STANDARD UE: EN149: 2001 + A1: 2009
- Registrazione su ISS (Istituto Italiano della Sanita)



3750 pezzi / cartone

50 pezzi/ scatola



60.5 * 52.5 * 47 cm (cartone)



G.W. 17.3 KG / cartone

N.W. 12.3 KG / cartone



Luogo di fabbricazione: : Chuzhou, Anhui , Cina

M78 - Mascherina protettiva a 3 strati (tipo I)

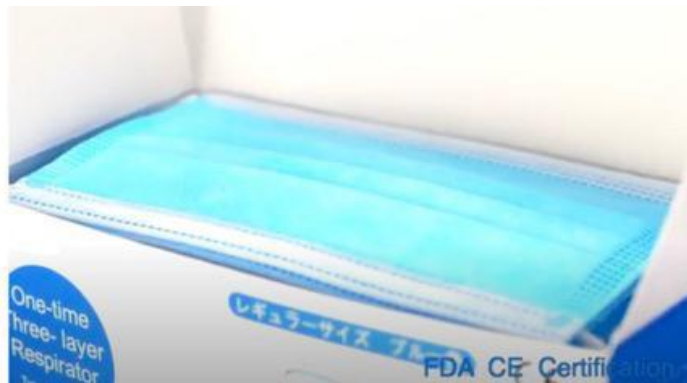

Sommario

- Maschera monouso in polipropilene non tessuto a 3 strati, spun-bonded, pieghettata piatta.
- Monouso, con elastici per le orecchie, clip per il naso
- Efficienza di filtrazione batterica BFE: 95%



Certificazioni:

- CE (Dichiarazione di conformità) e STANDARD UE: EN149: 2001 + A1: 2009, EN 14683: 2019 (Tipo I),
- STANDARD CINA: GB / T 32610-2016



3750 pezzi / cartone

50 pezzi/ scatola



60.5 * 52.5 * 47 cm (cartone)



G.W. 17.3 KG / cartone

N.W. 12.3 KG / cartone



Luogo di fabbricazione: : Chuzhou, Anhui , Cina

2. Camici e tute di protezione

PS91 - Tuta protettiva non sterile tipo 5-B / 6-B



Sommario

- Tuta protettiva monouso, con cappuccio incorporato, elastico in vita per una vestibilità comoda
- 5 taglie disponibili: S-2XL



Certificazioni:

- CE, STANDARD: EN 13688, EN 13034, EN ISO 13982, EN 14126



45 pezzi confezionati singolarmente in un involucro di plastica con cinturino / cartone



40 * 60 * 40 cm (cartone)



G.W. 9.3 KG / cartone



Luogo di fabbricazione: : Istanbul, Turchia

PS95 - Tuta protettiva non sterile tipo 5-B / 6-B



Weight 55-57/60gr/m²

MEASURING POINTS	SIZES	1	2	3	4	5	6	
		S	M	L	XL	2XL	3XL	
A	WAISTBAND	CM	60	62	64	66	68	70
B	LENGTH	CM	202	204	206	208	210	212
C	ARM LENGTH	CM	74	75	75	76	78	80



Sommario

- Tuta intera, con cappuccio con elastico, zip frontale coperta da patta e sottogola adesivo, elastico alle caviglie e ai polsi.
- DPI III, Tipo 5B / 6B
- Taglia: S, M, L, XL, 2XL, 3XL
- 100% polipropilene + rivestimento in polietilene laminato
- Senza latex



Certificazioni:

- CE, certificato TUV, STANDARD UE: EN 13688: 2013, EN13034: 2005 + A1: 2009, EN ISO 13982-1, EN 14126



45 pezzi confezionati singolarmente in un involucro di plastica con cinturino / cartone



40 * 60 * 40 cm (cartone)



G.W. 9.3 KG / cartone



Luogo di fabbricazione: : Istanbul, Turchia

PS87 - Camice sterile / non sterile



Sommario

- Materiale non tessuto, idrorepellente traspirante, con polsini elasticizzati, comodo da usare, alta qualità e protezione
- Dimensioni: standard



Certificazioni:

- CE, EU STANDARD: EN ISO 13688, EN 13034+A1, EN 14126



70 pezzi confezionati singolarmente in un involucro di plastica con cinturino / cartone



40 * 60 * 40 cm (cartone)



G.W. 8.1 KG / cartone



Luogo di fabbricazione: : Istanbul, Turchia

PS88 – Camice da visitatore 20gr



Sommario

- Materiale non tessuto, confortevole e di alta qualità



Certificazioni:

- CE, STANDARD: EN 13688, EN 13034+A1:2009, EN 14126



70 pezzi confezionati singolarmente in un involucro di plastica con cinturino / cartone



40 * 60 * 40 cm (cartone)



G.W. 8.1 KG / cartone



Luogo di fabbricazione: : Istanbul, Turchia

3. Occhiali a maschera / Occhiali a stanghetta / Visiere

PG18 – Occhiali a maschera

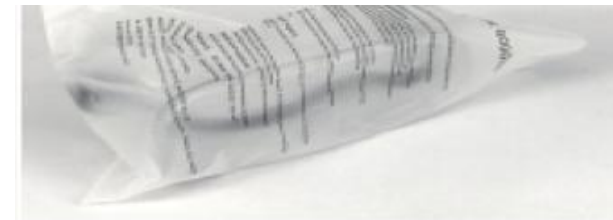
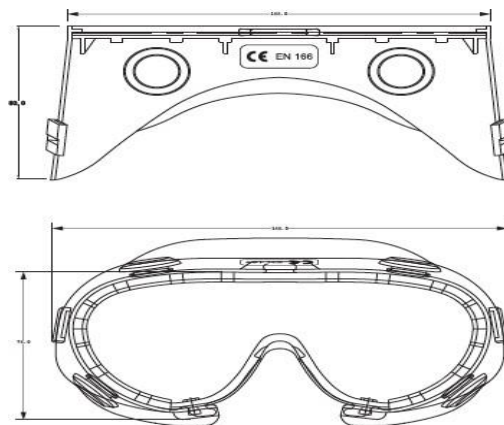

Sommario:

- Occhiali protettivi, non sterili
- Lente in policarbonato con montatura in cloruro di polivinile



10 pezzi individualmente confezionati/ scatola,
200 pezzi / cartone



74 * 33 * 46 cm (cartone)



Certificazioni:

- CE: EU - EN 166:2001



G.W. 17.5 KG / cartone

N.W. 16.5 KG / cartone



Luogo di fabbricazione: Wenzhou, Cina

PG19 – Occhiali a stanghetta



Sommario:

- Occhiali di sicurezza, non sterili
- Composizione: lente e montatura in policarbonato



10 pezzi individualmente confezionati/ scatola,
300 pezzi / cartone



82 * 69 * 23 cm (cartone)



Certificazioni:

- CE: EU – EN 166:2001



G.W. 18 KG / cartone

N.W. 16.8 KG / cartone



Luogo di Fabbricazione: Wenzhou, China

PG20 - Visiera

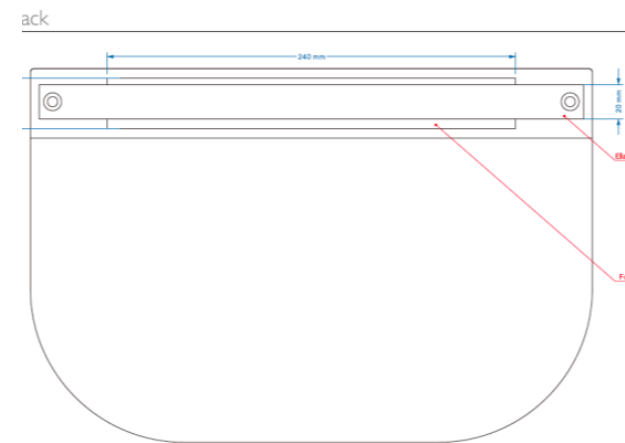

Sommario:

Composizione:

- 1 Schermo: PET
- 2 Bottone: nylon
- 3 Fascia elastica: poliestere
- 4 Striscia di schiuma: poliuretano espanso
- 5 Pellicola protettiva: PE



Certificazioni:

- CE: EU - EN 166:2001



200 pezzi / cartone



68 * 38 * 28 cm (cartone)



G. W. 11 KG / cartone

N. W. : 10 KG/cartone



Luogo di Fabbricazione: Wenzhou, China

4. Guanti in nitrile

G17 – Guanti in nitrile

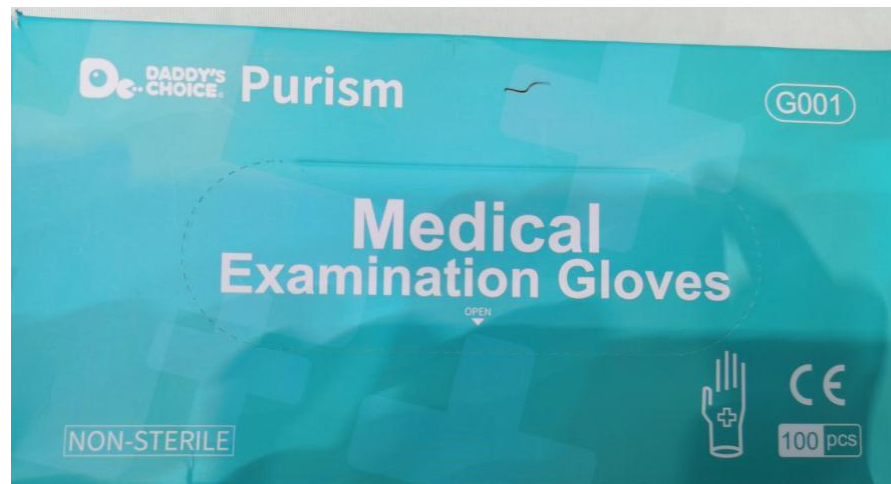

Sommario:

- Guanti da esame in nitrile senza polvere, monouso
- Classe I
- Cinque taglie: XS, S, M, L, XL



Certificazioni:

- CE, STANDARD: EN ISO 14971: 2012 EN ISO 15223-1:2016 EN
- 1041:2006+A1:2013 ISO 10993-1:2018 EN ISO 10993-5:2009 EN ISO
- 10993-10:2013 EN 455-2:2015
- Registrazione su ISS (Istituto Italiano della Sanità)



100 pezzi / scatola

1000 pezzi/ cartone



38*23.5*23.5 cm (cartone)



G. W: 5.8 KG / cartone

N. W. : 4.8 KG/cartone



Luogo di Fabbricazione: Dezhou, China

5. Test rapidi

051 - Test rapido per rilevamento antigene



Sommario:

- Periodo di rilevamento 15 minuti, prestazioni eccellenti rispetto al test PCR
- Per uso professionale, funziona con tamponi nasali e faringei
- Utilizza la tecnologia del flusso laterale
- Sensibilità 85,00% (95% CI: 63,96% - 94,76%)
- Specificità 100,00% (95% CI: 96,30% - 100,00%)
- Concordanza complessiva 97,50% (IC 95%: 92,91% - 99,15%)



25 Test /scatola 1250 Test/cartone



70.3 * 51.3 * 36.3 cm (cartone)



Certificazioni:

- Certificato CE
- Dichiarazione di conformità.
- Prodotto registrato sul sito ISS (Istituto Superiore di Sanità)



G. W. : 15.8 KG



Luogo di fabbricazione: Beijing, Cina

051 – Test rapido per rilevamento anticorpi



Sommario:

- Periodo di rilevamento 10 minuti
- Per uso professionale, funziona con sangue, siero e plasma
- Test per 2 anticorpi IgM e IgG contemporaneamente
- Sensibilità 93,3% Specificità 98,2%



Certificazioni:

- Certificato CE
- Dichiarazione di conformita.
- Prodotto registrato sul sito ISS (Istituto Superiore di Sanità)



25 Test /scatola 1250 Test/cartone



61 * 46 * 37 cm (cartone)



G. W. : 13.6KG



Luogo di fabbricazione: Beijing, Cina

6. Altro

Pulsossimetri



Sommario:

- Display TFT. Può visualizzare la saturazione di ossigeno nel sangue, la frequenza del polso, l'indice di perfusione sanguigna, l'istogramma dell'intensità del polso.
- Intervallo di misurazione SpO2: 35% ~ 99%, PR: 30 bpm ~ 240 bpm, PI: 0,2% ~ 20%
- Precisione della misurazione SpO2: 90% ~ 99% ± 1%, PR: ± 1 bpm, PI: 0,2% ~ 2%, 2% ~ 10% ± 1%; 10 ~ 20% ± 2%



Certificazioni:

- Certificato CE
- Standard e regolamenti: EN13485, GB2626-2006



200 pezzi/cartone



36.4 * 42.5 * 35.5 cm (cartone)



G. W. : 14KG (cartone)



Luogo di fabbricazione: Shenzhen, Cina

Aghi e Siringhe



Sommario:

- 1 ml Leur lock senza ago
- Luer lock da 3 ml senza ago
- Luer lock da 5 ml senza ago
- Aghi 22G 5/8 " - 22G 1,5" - 25G 5/8 " - 25G 1,5" - 21G



Certificazioni:

- Certificato CE
- Prodotti registrati sul sito ISS (Istituto Superiore di Sanità)



3000pezzi/cartone (3ml luer lock) -
2400pezzi/cartone (5ml luer lock)
10000pezzi/cartone (aghi)



61*37.5*48.5cm (3ml luer lock) -
63.5*40.5*40.5cm (5ml luer lock)
50*42*42cm (aghi)



16KGS/18KGS (3ml luer lock) -
16KGS/18KGS (5ml luer lock)
17KGS/19KGS (aghi)



Luogo di fabbricazione: Luzhou, Cina

Contattaci



Uffici: +39 0932 1915838

email: ordini@primexitalia.org

mobile +39 370 105 4200 (orari 9:00-20:00 Lun-Sab)

hotline +39 368 713 0722 (reperibile 24/24h)

whatsapp +39 371 152 6938 (orari 9:00-20:00 Lun-Dom)